

Original Research Article

<https://doi.org/10.20546/ijcmas.2020.905.007>

Wear Characteristics and Material Composition of Austempered Ductile Iron (Fe: 84.33 %, C: 5.30 %) Rotavator Blades

Rajat Arya¹, Raushan Kumar^{2*} and R. N. Pateriya³

Department of Farm Machinery and Power Engineering, GBPUA&T, Pantnagar,
Udham Singh Nagar, Uttarakhand 263145, India

**Corresponding author*

ABSTRACT

Rotavator is an efficient tillage implement used for rapid bed preparation and is energy and time efficient equipment for different soils compared to all other conventional tillage implements. The primary cause that limits the persistence of rotavator is wear of its blades. This paper was undertaken to study the material composition and wear characteristics of austempered ductile iron third edition (ADI 3rd edition) rotavator blades which were developed by austempering heat process done over cast iron. The objective was carried out by means of elemental analysis and identification of wear pattern of rotavator blades with increase in operational time. The results indicated that the change in material composition responsible for wear characteristics of blades. Iron and carbon content was decreased from 84.33 and 5.30 % to 72.4 and 4.20 % respectively. Weight loss of 140.2 g was observed in austempered ductile iron (Fe: 84.33 %, C: 5.30 %) rotavator blades.

Keywords

Tillage Implement, wear analysis, material analysis, rotavator blade.

Article Info

Accepted:
05 April 2020
Available Online:
10 May 2020

Introduction

Farm mechanization has been a key concern for our policy makers where overall level of mechanization is only about 40 to 45% in which contribution of mechanical and electrical power sources is almost about 90% of the total power. Improved farm machines and equipment's reduces the drudgery of operations and also increases the quality of

work. Rotavator is tillage tool used for seed bed preparation and controlling of weed in arable field condition.

It comprises of blades mounted on a flange which is fixed on a shaft, and the shaft is driven by PTO of a tractor through combination of differential gears and chain. Rotavator facilitate rapid seedbed preparation and reduces the draft in comparison to the

conventional tillage implements. It saves 20 to 25% of cost of operation, 30 to 35% of time of operation compared to tillage carried out by ploughs, harrows and cultivators. (Bukhari, *et al.*, 1996) conducted a study that the degree of soil pulverization obtained by the rotavator was compared with the usage of harrow (twice), mould board plough, spiked tooth harrow is not significant different.

Rotavator blades being subjected to abrasive wear and fatigue under dynamic loading conditions needs replacement after the use of 100-150 hours in case of our Indian blades. (Yatsuk *et al.*, 1981) reported that the material used in manufacturing of rotavator blades affect their useful life. L shaped blades are most suitable for Indian farming conditions reason being, it does not pulverize the soil too much. But still the wearing of blades takes place after certain hours (80-100 hours) of operation, which must be overcome to increase the service life of the blades. Most frequent problem that occurs with rotavators are wearing of rotavator blades which increases the draft and energy requirement for working of rotavators. Studies are being carried out on various material compositions of rotavator blades, and one such material which has gained attention for manufacturing of rotavator blades is ADI (Austempered Ductile Iron) due to its exceptionally good blend of low cost, toughness, fatigue strength, and wear resistance (Rana, *et al.*, 2016). Cast iron is converted into ADI through an attractive thermal process known as austempering. Austempering of cast iron consists of three steps: austenitizing of the cast iron matrix, rapid cooling to the isothermal treatment temperature and isothermal treatment usually in the range of 250°C–450°C (Kumain, *et al.*, 2017). ADI (3rd edition) rotavators blades are the newly developed blades fabricated at Central Mechanical Engineering Research Institute, Durgapur, West Bengal, India. In order to observe the characteristics of the developed

blades and the efficiency it would bring to the tillage operation done by rotavator, present study was carried out with the following objectives include to study material composition of ADI (3rd edition) rotavator blades. And to study wear characteristics of rotavator blades in actual field conditions.

Materials and Methods

In this paper, main our main motive to study the wear characteristics and material composition of ADI (3rd edition) rotavator blades. The determination of material composition and wear pattern of rotavator blades were carried out for 100 hours of operation at a time interval of 10, 30, 50, 70, 90 and 100 hours.

Specification of rotavator blades

The ADI (3rd edition) rotavator blades selected for the study were manufactured and supplied by CSIR-Central Mechanical Engineering Research Institute, Durgapur, West Bengal, India. ADI (3rd edition) rotavator blades were made of ductile cast iron. The dimensions of ADI (3rd edition) blades are shown in Fig-1.

Surface characteristics of selected rotavator blades

Surface characteristics of ADI (3rd edition) rotavator blades were determined with the use of Scanning Electron Microscope (SEM). Electron microscope produces images of a sample by scanning the surface with a focused beam of electrons which interacts with atoms in the sample and produces various signals containing information about the surface topography and composition of the sample. Elemental analysis and imaging of the blade was performed with the provision of Energy Dispersive Spectrometer (EDS) equipped in Scanning Electron Microscope. A beam of X-

rays or high energy beam of charged particles (electrons or protons) were focused on the sample being studied. When an incident beam interacted with the sample in rest position, then an electron in inner shell of the atom got agitated and left the shell, hence creating an empty hole, on which an electron from a high energy shell occupies the hole and the difference in the energy between higher and lower energy shell was released in the form of X-ray. The energy and number of X-rays emitted from the specimen was measured by energy-dispersive spectrometer.

As the energies of the X-rays are characteristic of the difference in energy between the two shells and of the atomic structure of the emitting element, EDS allowed the elemental composition of the specimen to be measured. For determining the surface characteristics of rotavator blade firstly a sample section of blade shown in Fig. 2 was cut in the size (40 mm × 8 mm × blade thickness) and then cleaned with acetone solution in order to remove all the impurities. After the sample was prepared it was inserted in the specimen chamber of SEM and was rigidly mounted on a holder known as specimen stub. The SEM records automatically the elemental composition and surface morphology of the specimen sample in an attached computer shown in Fig 3.

Experimental treatments

The study on material composition and wear characteristics of rotavator blades were carried out with ADI (3rd edition) rotavator blades. An 8 flange rotavator of width 210 cm was used for the experiment as shown in Fig. 4.

Wear measurement of rotavator blades

During the study the wear of rotavator blades was measured dimensionally as well as

gravimetrically. The blades were allowed to run for almost 100 hours and the wear was measured at an interval of each 20 hours. The procedures for measuring both gravimetric wear and dimensional wear are described below.

Gravimetric wear of rotavator blades

Gravimetric wear of rotavator blades provides reduction in weight of the blade material. Initially the weight of all rotavator blades was measured using an Electronic Balance (weighing range of 0 – 3.100 g) as shown in Fig. 5(a). After each 20 hours of working, the blades were dismounted from the rotavator and were firstly washed in clean water and secondly in dilute acetone solution so that all impurities left in the blade surface were removed completely. The difference in initial weight and final weight of blade for total 100 hours of operation gave the cumulative wear of rotavator blade.

Dimensional wear of rotavator blades

Dimensional wear deals with the wear of rotavator blades with respect to its width and thickness. This was measured with the use of “Grid method”, in which blade was divided along its length into 10 divisions of 2 cm each. An ordinary graph paper was pasted on inner side of the blade by aligning points of the blade and forming a grid of 2 cm × 2 cm, as shown in the Fig. 5(b). Width of rotavator blade was measured at each marked points along the length of the blade with help of digital vernier calliper having least count of 0.01 mm. The width was measured from 0th point on the blade section upto 10th point on the leg section. The width of the blades were measured at all points before starting of operation and same procedure was followed after successive interval of 10, 30, 50, 70, 90 and 100 hours as shown in Fig. 5(b).

Digital micrometer of least count 0.01 mm

was used to measure thickness of the blade which was another aspect of wear. Thickness was measured at each grid point along the width of the blade and for compensating the thickness of graph paper a deduction of 0.07 mm from micrometer reading was made.

The thickness of the blades were measured at all points before the starting of operation, and same procedure was followed after successive interval of 10, 30, 50, 70, 90 and 100 hours.

Field evaluation parameters

The field tests were conducted at E-20 field of Norman Borlaug Crop Research Centre of Govind Ballabh Pant University of Agriculture and Technology, Pantnagar, Udham Singh Nagar, Uttarakhand (India). All parameter associated with field evaluation of rotavator is given in Table 2.

Results and Discussion

The outcomes of the study are presented and discussed in this part of paper. Which contains the elemental analysis as well as wear analysis of ADI (3rd edition) rotavator blades. The elemental analysis of these blades was done with elemental distribution on the surface of rotavator blades. The wear analysis was carried out on gravimetric (weight) as well as on dimensional basis.

Surface characteristics of selected rotavator blades

Surface characteristics of ADI (3rd edition) rotavator blades were obtained with the use of Scanning Electron Microscope (SEM). Top surface of the blade section was the area where imaging and chemical analysis were performed. Elemental analysis was done twice, once before the operation started and again after the run of 100 hours. Elemental distribution of rotavator blades at initial

condition of 0 hour of working along the blade section are presented from Table 3. It was observed that carbon content in ADI (3rd edition) was more, which gave it an extra edge in increasing its strength.

The elemental distribution of all the rotavator blades after the working period of 100 hours is shown from Table 4. In ADI (3rd edition), Iron (Fe) content was reduced from 84.33 % to 72.4 % and carbon content was reduced to 4.02 %. Also unnormalised concentration in weight percent was reduced from 100.00 % to 85.91 %.

Imaging of rotavator blades

On the basis of surface analysis of rotavator blades, spectrum was obtained and imaging of rotavator blades was done which is presented from Fig. 6. From the study it was found that percentage of elements on the blade surface varied, also with increase in working hours there was a significant decrease or increase in percentage of various elements. Therefore, indicating that the surface characteristics of blades varied strongly affecting the wear characteristics of rotavator blades.

Identification of wear pattern of blades

Wear pattern of ADI (3rd edition) rotavator blades were studied by observing the reduction in weight of each rotavator blades during the time interval of 10, 30, 50, 70, 90 and 100 hours. Wear pattern of blades were identified by measuring the reduction in their dimensions (width and thickness) at different points marked on the graph paper pasted on blade surface at time interval of 10, 30, 50, 70, 90 and 100 hours.

Gravimetric wear of rotavator blades

The average of ten rotavator of ADI (3rd edition) was taken for measurement of weight

loss. Initial average weight, cumulative weight loss and gravimetric wear rate of ADI (3rd edition) rotavator blade is shown in Table 5.

Dimensional wear of rotavator blades

Results of dimensional wear was obtained with respect to width and thickness for ADI (3rd edition) rotavator blade.

Reduction in width of selected rotavator blades

Table 6 shows the average width of ADI (3rd edition) rotavator blade at different operation hours of 10, 30, 50, 70, 90 and 100. Initial average width of ADI (3rd edition) rotavator blades at 0th point (0 mm) along the blade section was 76.46 at 6th point (120 mm) along the bent section was 86.38 and at 10th point (200 mm) along the leg section was 83.26.

After the operation of 100 hours the average width of ADI (3rd edition) rotavator blades at 0th point (0 mm) along the blade section was 42.21 at 6th point (120 mm) along the bent section was 67.82 and at 10th point (200 mm) along the leg section was 80.15. The data revealed that with increase in operation time, average width at all points along the length of the blade decreases. The data obtained also revealed that maximum loss in width occurred at blade section followed by bent and then leg section.

Table 7 shows the average cumulative wear loss in the width of ADI (3rd edition) rotavator blade at different operation hours of 10, 30, 50, 70, 90 and 100. The average cumulative wear loss in width of ADI (3rd edition) rotavator blade after 100 hours of operation at

0 mm point along the blade section was 34.25, at 120 mm point along the bent section was 18.56 and at 200 mm point along the leg section was 3.11.

Reduction in thickness of selected rotavator blades

The average wear loss in thickness of rotavator blades after the operation of 100 hours in field conditions for ADI (3rd edition) rotavator blades has been given from Table 8. From the data presented it was observed that reduction in thickness for ADI (3rd edition) rotavator blade was maximum at blade section (0th point), followed by bent section (6th point) and leg section (9th point).

At 0th point for ADI (3rd edition) rotavator blade initially the thickness of rotavator blade was found to be 7.6 mm which was reduced to 5.31 mm after working period of 100 hours. Before the commencement of operation at (0, 70 mm) point, thickness was 4.12 mm, which was reduced to 1.6 mm after the working period of 30 hours. But after 50 hours of working the width of blade was reduced to less than 70 mm therefore, thickness of the blade was considered as 0 mm. It was also seen that at (0, 60 mm) point, initially thickness of the blade was 7.6 mm, which was reduced to 3.25 mm after the working period of 70 hours. But after 90 hours width of blade was reduced to less than 60 mm therefore, thickness could not be measured and was considered as 0 mm.

For ADI (3rd edition) rotavator blade, reduction in thickness after operation of 100 hours at blade section (0, 0) was 2.29 mm, at bent section (120,0) was 2.12 mm, and at leg section (180,0) was 1.74 mm.

Table.1 Dimensions of ADI (3rd edition) rotavator blade (All dimensions are in mm)

Parameters	Values
Blade span, mm	86
Effective vertical length, mm	160
Blade cutting width, mm	140
Blade thickness, mm	7.6
Sweep back angle	3°
Blade section width, mm	76
Hole diameter, mm	15

Table.2 Field evaluation parameters

Parameters	Values
Forward speed of prime mover	3.50 – 4.50 km/h
Speed of rotor shaft	210 rpm
Depth of cut	80 – 100 mm
Width of cut	1.86 m
Draft of rotavator	3305 N
Bulk density	1.541 g/cc
Moisture content	15 – 18 %
Actual field capacity	0.40 ha/h
Theoretical field capacity	0.65 ha/h

Table.3 Elemental distribution of ADI (3rd edition) rotavator blade initially

Element	Atomic number	Series	Unnormalised. C [wt. %]	Error [wt. %]
Fe	26	k-series	84.33	2.1
C	6	k-series	5.30	1.6
O	8	k-series	4.12	0.9
Si	14	k-series	2.88	0.5
Mg	12	k-series	0.97	0.4
		Total	100.00	

Table.4 Elemental distribution of ADI (3rd edition) rotavator blade after 100 hours

Element	Atomic number	Series	Unn. C [wt. %]	Error [wt. %]
Fe	26	k-series	72.4	2.4
O	8	k-series	4.08	1.4
C	6	k-series	4.02	0.4
Si	14	k-series	2.19	0.3
Mg	12	k-series	1.95	0.3
Cr	24	k-series	0.37	0.1
Al	13	k-series	0.48	0.1
Ni	28	k-series	0.42	0.1
		Total	85.91	

Table.5 Gravimetric wear analysis of ADI (3rd edition) rotavator blade at different working hours

Working Hour	Average weight of blades, g	Cumulative weight loss of blades, g	Gravimetric wear rate, g/h
0	1165	0	0
10	1157.2	7.8	0.78
30	1135.8	29.2	0.973
50	1115.25	49.75	0.995
70	1087.02	77.98	1.114
90	1062.5	102.5	1.139
100	1024.8	140.2	1.402

Table.6 Average width of the ADI (3rd edition) rotavator blades at different working hours

Working Hours, h	Points along the length of the blade, mm										
	0	20	40	60	80	100	120	140	160	180	200
0	76.46	78.2	80.01	82.5	84.05	85.12	86.38	86.21	85.44	84.32	83.26
10	75.16	77.46	79.39	82.17	83.76	84.87	86.17	86.02	85.33	84.21	83.15
30	70.58	73.28	75.86	78.75	81.14	83.11	84.79	85.08	84.35	83.31	82.35
50	66.34	69.78	72.38	76.29	79.95	82.4	84.28	85.37	84.21	83.27	82.17
70	63.65	66.7	70.2	73.98	77.82	80.99	83.27	83.65	83.93	83.21	82.16
90	51.23	53.37	57.89	62.69	68.84	73	76.15	78.1	78.63	81.35	80.71
100	42.21	45.05	48.1	53.39	56.44	61.67	67.82	70.98	73.31	78.09	80.15

Table.7 Average cumulative width loss of the ADI (3rd edition) rotavator blades at different working hours

Working Hours, h	Points along the length of the blade, mm										
	0	20	40	60	80	100	120	140	160	180	200
0	0	0	0	0	0	0	0	0	0	0	0
10	1.3	0.74	0.62	0.33	0.29	0.25	0.21	0.19	0.11	0.11	0.11
30	5.88	4.92	4.15	3.75	2.91	2.01	1.59	1.13	1.09	1.01	0.91
50	10.12	8.42	7.63	6.21	4.10	2.72	2.01	1.93	1.23	1.05	1.09
70	12.81	11.5	9.81	8.52	6.23	4.13	3.11	2.56	1.51	1.11	1.10
90	25.23	24.83	22.12	19.81	15.21	12.12	10.23	8.11	6.81	2.97	2.55
100	34.25	33.16	31.91	29.11	27.61	23.45	18.56	15.23	12.13	6.23	3.11

Table.8 Average cumulative thickness of blade at different point of ADI (3rd edition) rotavator blade at different working hours

Working hours, h	Average thickness of blade, mm		
	0 th (0 mm)	6 th (120 mm)	9 th (180 mm)
0	0	0	0
10	0.08	0.02	0.09
30	0.88	1.06	0.36
50	1.48	1.48	0.59
70	1.67	1.67	0.97
90	2.08	1.9	1.29
100	2.29	2.12	1.74

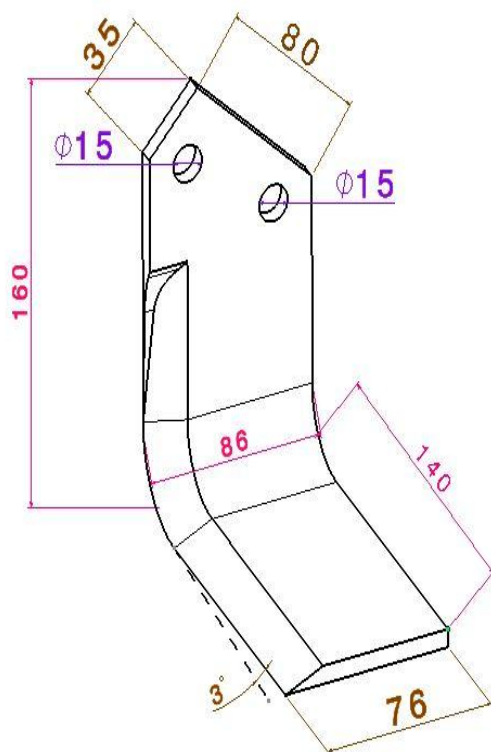

Fig.1 Dimensions of ADI (3rd edition) rotavator blade (All dimensions are in mm)



Fig.2 Sample section of ADI (3rd edition) rotavator blade

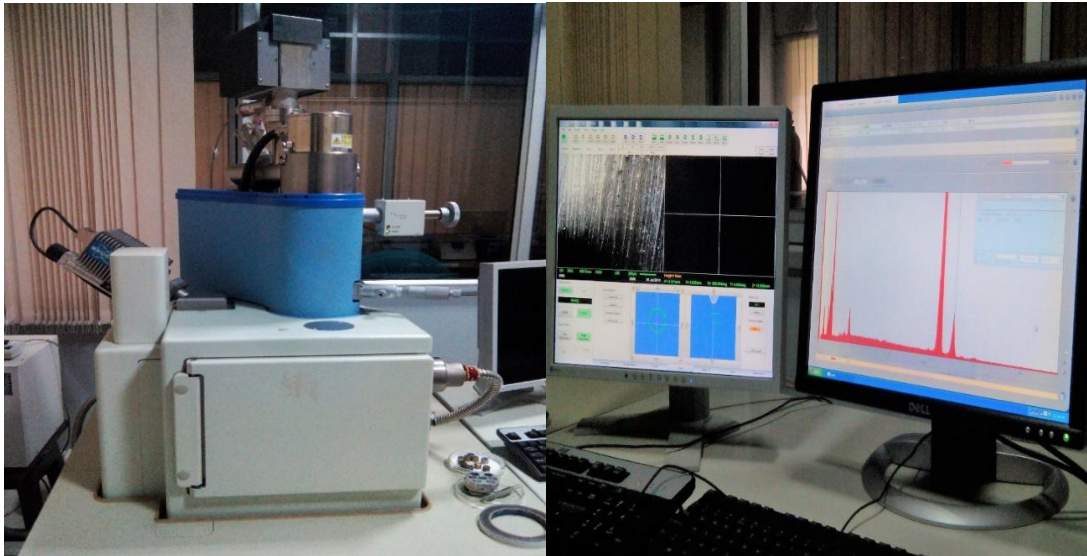

Fig.3 Scanning electron microscope with attached computer



Fig.4 Rotavator with 8 flange and width of 210 cm



(a) Weight measurement (b) width measurement
Fig.5 Wear measurement

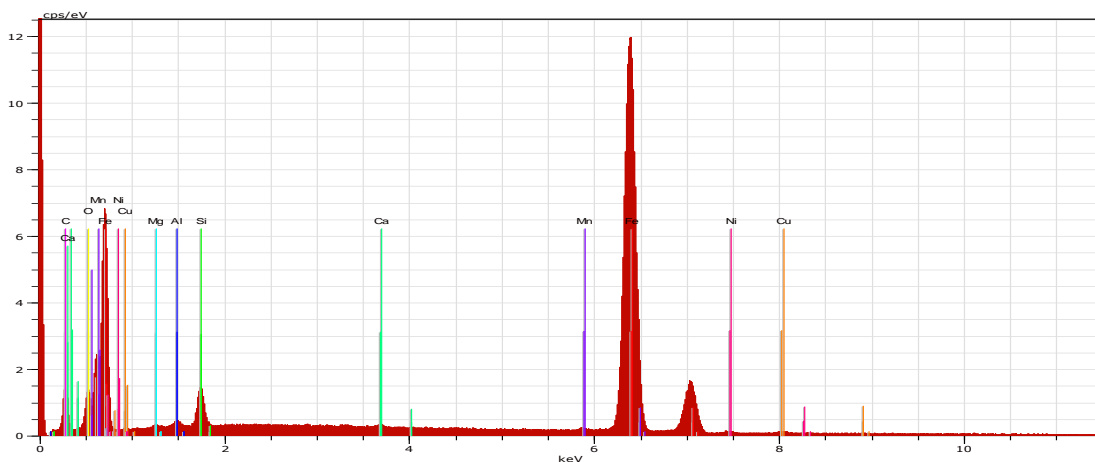

Fig.6 Spectrum of ADI (3rd edition) rotavator blade at 0 hour

Rotavator saves time, cost and energy of operation and provides higher quality of work as compared to other tillage implements. Despite of consuming high power, rotavator is energy efficient and time efficient equipment for different soils compared to all other conventional tillage implements. But due to the rapid wear of rotavator blades the use of rotavator becomes restrictive for the farmers.

The material composition of ADI (3rd edition) rotavator blades before the operation and after the operation of 100 hours were carried out

with imaging of blade section, bent section and leg section of the blade. Therefore, from the study following conclusions were drawn:

The surface characteristics of rotavator blades revealed that chemical composition of blades varied with increasing working hours. Carbon content responsible for the hardenability of rotavator blades ADI (3rd edition) with 5.30. It was also observed that with increase in working hours the percentage of elements along the blade section decreases and the

decrement in percentage of elements with the increase in working hour effects the wear characteristics of rotavator blades.

The identification of wear pattern of ADI (3rd edition) rotavator blades revealed that cutting edge of blade section was most prone to wear. It was evident that with increase in working hours the weight of rotavator blade decreases.

It was observed that reduction in thickness was maximum at blade section (0th point), followed by bent section (6th point) and leg section (10th point)

The overall average wear rate of ADI (3rd edition) rotavator blades after 100 hours of operation was 0.915 g/h.

References

- Kumain, A., Pateriya, R. N., Sharma, R. K., Ashish Chaudhary and Bhattacharya, T. K. (2017). International Journal of Basic and Applied Agricultural Research, 15(3), 179-185.
- Rana, M., & Pateriya, R. N. (2016). A study on ADI rotavator blades. Res. Environ. Life Sci. 9(7) 871-874.
- Yatsuk, E. P., 1981. Rotary soil working machines: construction, calculation and design, Amerind publication, New Delhi, India.

How to cite this article:

Rajat Arya, Raushan Kumar and Pateriya. R. N. 2020. Wear Characteristics and Material Composition of Austempered Ductile Iron (Fe: 84.33 %, C: 5.30 %) Rotavator Blades. *Int.J.Curr.Microbiol.App.Sci.* 9(05): 76-87. doi: <https://doi.org/10.20546/ijcmas.2020.905.007>