

Original Research Article

<https://doi.org/10.20546/ijcmas.2020.903.254>

Electrostatic Conversion Kit for Conventional Knapsack Mist-blower: Development and Performance Evaluation

Dipak S. Khatawkar^{1*}, D. Dhalin² and P. Shaji James²

¹Department of Farm Machinery and Power Engineering, Kelappaji College of Agricultural Engineering and Technology, Tavanur, India

²Department of Agricultural Engineering, College of Agriculture, Vellayani, India
Agricultural Research Station Mannuthy, Kerala, India

**Corresponding author*

ABSTRACT

An electrostatic induction spray charging system as attachment to powered knapsack mist-blower was developed and evaluated for the performance. A high voltage generator was fabricated on the basis of Cockcroft-Walton voltage multiplier principle with input of 6 V DC battery to provide high voltage required at the developed charging electrode assembly (Model-I and II) for inducing electrostatic charge on spray droplets. The working prototypes were evaluated for charge to mass ratio (mC.kg^{-1}) at five electrode potentials (1 kV, 2 kV, 3 kV, 4 kV and 5 kV), four electrode placement positions (0 mm, 5 mm, 10 mm and 15 mm) and five distances (50 cm, 100 cm, 150 cm, 200 cm and 250 cm) from the nozzle. Model-II with electrode voltage potential at 5 kV and EPP at 5 mm shown the maximum CMR value (1.088 mC.kg^{-1}). In contrast with commercial system (ESS-MBP90) it was observed that except at 50 cm distance from nozzle, Model-II (at 4 kV and 5 kV) surpassed commercial system in CMR from 100 cm to 250 cm distance. To avoid air blast injury of plant, the nozzle has to be 100 cm to 150 cm away from the plant. The droplet spectrum of the developed system was analyzed and observed that the size of droplets were 100 to 200 μm . The deposition efficiency of the developed system was on par with that commercial unit, and was within the range of 60 to 70 per cent. The developed system found to be cost effective and significantly consistent than the commercial system.

Keywords

Electrostatic, voltage multiplier, droplet spectrum, charge-to-mass ratio

Article Info

Accepted:

15 February 2020

Available Online:

10 March 2020

Introduction

In commercial agriculture, plant protection chemicals are vital for profitability, low food prices and for maintaining adequate food supply. Without them, crop losses could be as high as 50 per cent for field crops and up to 100 per cent for fruit crops and greenhouse ornamentals (Oerke, 2006). The demand for

plant protection machinery in India is increasing every year. In the country, the powered knapsack mist blower is one of the most popular and versatile pesticide application equipment because of its simplicity, ease of operation and inexpensiveness. But still these sprayers have to overcome the problems of low target deposition, distribution and penetration into

the plant canopies. An introduction of electrically charged sprays for agricultural application can provide greater control of droplet transport with impending reduction of wastage. The use of electrostatic spraying can increase the application efficiency by about 80 per cent with 60 per cent less spray chemical ingredients (Lane and Law, 1982; Anantheswaran and Law, 1989). Electrostatics, the study of static electricity, the surface phenomenon governing electric charges accumulated on a body as explained by Coulomb's law. It has significant potential on application of agricultural liquid formulations since charged particles can perform uniform spray coverage with considerably less quantity (Carlton and Bouse, 1980).

Majority of agricultural chemicals are applied as water-based formulations. Water has a polar molecular structure and has a large value of electric dipole moment due to hydrogen covalent bonds. The electron-pair forming covalent bond gets attracted towards the oxygen atom and as a result oxygen side gets slight negative polarity and hydrogen side gets slight positive polarity which induces an electric dipole moment within the water molecule (Jorg and Launter, 2006; Gupta *et al.*, 1994)). On the basis of electro-chemistry of polar molecules, fine water droplets can be charged electrostatically. The plants grounded to the earth shall be at zero potential, even though the metabolic processes of living plant body induce a slight positive charge on the plant (Mouel *et al.*, 2010; Smith *et al.*, 1977).

But this charge has been found to be distributed asymmetrically on plant surface, concentrated near the sharp protruding body parts such as leaf tips, spikes and especially floral parts (Oyarace and Luis, 2010). In India, only a few attempts have been made so far in developing and testing indigenous

electrostatic spray charging systems. Moreover, the development of an economical electrostatic spray charging system for an existing sprayer would be an advantage to the Indian farmer. Hence, the development an electrostatic induction charging attachment to a conventional engine powered knapsack mist-blower was contemplated.

Materials and Methods

Principles of electrostatic induction spray charging system

The method of electrostatic induction spray charging was adopted for this study by considering its known advantages over other charging methods such as high charge transferability, less hazardous to life and simplicity in construction. Fig. 1 illustrates the schematic arrangement of the components and working principle of an electrostatic induction spray charging system which has been adopted.

The system consisted of a spray nozzle and electrode placed in the vicinity of spray atomization zone concentrically with the spray nozzle. When sufficiently high voltage DC potential was applied to the charging electrode and the spray liquid was grounded, an electrostatic field would create around the electrode (Luciana and Cramariuc 2009; Maynagh *et al.*, 2009; Alamuhan and Maghirang, 2010). The position of the electrode was fixed in such a way that it was exposed to the maximum spray atomization area. According to Gauss's Law, the maximum droplet charging occurs when the droplet formation zone is exposed to the maximum field strength. Therefore, for any liquid having non-zero electrical conductivity, an excess image charge will be accumulated on the grounded spray liquid with opposite polarity (Yu *et al.*, 2011; Mamidi *et al.*, 2012; Robson *et al.*, 2013).

Electrostatic induction spray charging system

The design for an electrostatic induction charging arrangement for a conventional “duro-mist” nozzle was conceptualized based on available theoretical background of liquid particulate charging. Experimental prototype of induction charging nozzle attachment was developed to suit a knapsack mist blower. The powered knapsack mist blower selected for the study (Fig. 2) was OLEOMAC make AM 162 model with the following specifications.

Table.1

Power	: 4.5 HP, 3.3 kW
Displacement	: 61.3 cm ³
Max. air flow	: 20.0 m ³ min ⁻¹
Air speed	: 90 m s ⁻¹
Liquid delivery rate	: 0.67 – 5.00 L min ⁻¹
Liquid tank capacity	: 16.0 L
Weight	: 11.5 Kg

For charging an aqueous spray electrostatically, a high voltage DC power supply was essential. The basic voltage amplification unit mainly consists of a diode pump voltage multiplier. It has a special arrangement of P-N junction diodes and capacitors with an alternating current input. The voltage amplification depends upon the number of stages of diode and capacitor ladder and the capacitance value.

Voltage inverter circuit

In order to convert input DC voltage from battery into an amplified AC voltage, an inverter circuit was necessary. It consists of a pulse generator and a high voltage transformer, in which the input DC voltage was converted into a pulsating square wave signal through the pulse generator circuit. This pulsating voltage was applied across the

primary winding of the high voltage transformer, which then generates a sinusoidal alternating wave in the secondary winding due to mutual induction. This AC voltage can be used as an input source for the voltage amplification circuit.

Diode-pump rectification

A diode-pump rectifier circuit was developed as shown in Fig. 3. The figure illustrates the arrangement of diodes and capacitors with an AC voltage input (V). The circuit doubles the voltage output with a cascade arrangement of two diodes and two capacitors. However, the practical output voltage shows slight reduction due to ripple in the voltage amplification. This voltage doubler or multiplier circuit generally known as the Cockcroft-Walton voltage multiplier (Fig. 4). The theoretical output voltage could be calculated by the formula as,

$$V_{Output} = 2 \times N \times V_p$$

Where,

V_p = Peak value of voltage supply

N = Number of capacitors in the circuit

The practical voltage output differed slightly from the output voltage calculated theoretically due to the ripple effect in voltage amplification. Then it could be expressed in terms of Ripple voltage (V_R),

$$V_R = \frac{I \times N(N + 1)}{2 \times C \times F}$$

Where,

I = Load current, A

N = No. of capacitors

F = Driving Frequency, Hz

C = Capacitance, farads

This ripple voltage represents the difference between theoretical and practical voltage output from the C-W voltage multiplier

circuit. Considering the alternating sine wave input, the lower rectifier causes the series capacitor to charge to the peak voltage of the input wave form. This occurs during the negative going excursions of the wave form and during positive going half-cycle, the charged capacitor and the transformer become effective in the series. This series arrangement charges the output capacitor to the sum of these two voltages and in turn, become equal to the twice of the peak value of the transformer voltage. Fig. 4 illustrates the further arrangement of multiple numbers of the cascade stages of the Cockroft-Walton voltage multiplier for higher output voltages with required polarity, i.e. positive or negative high potential (Law, 1975; Bode and Bowen, 1991; Kihm *et al.*, 1992).

High voltage generator

A high voltage generator was fabricated on the basis of Cockroft-Walton voltage multiplier principle, using 6 V DC battery with 0.25 mA current as an input source. It consisted of a high voltage transformer with different stages of cascade multiplier having IN4007 diodes and 3 kV ceramic capacitors (1.8 μ F). A total five numbers of HVDC generators were fabricated (Fig. 5), so as to get an output voltage of 1000 V, 2000 V, 3000 V, 4000 V and 5000 V. As the voltage-multiplier circuit requires an AC input, an inverter circuit was introduced in between the DC input battery and the high voltage transformer.

The pulse generator in the inverter circuit was fabricated with NE555 standard timer Integrated Circuit and two 3296-Electronic Potentiometers to adjust the duty cycle and frequency. The entire HVDC generator unit was accommodated in an insulated box to avoid arcing, direct contact with the operator or with any other conducting materials to avoid any sort of casualty.

Exposed electrode carrier

The Fig. 6a and Fig. 6b illustrates geometry of the designed and fabricated HV-electrode assembly with the radial distance of electrode at 1.5 to 2.0 cm from the centre point of spray nozzle. The material for fabricating the assembly was selected on the basis of proper insulation as well as machinability, hence the Cast-Nylon-6 circular section rod of 75 mm diameter was used.

The electrode carrier was designed in such a way that, introduction of the electrode assembly to an existing system must not produce any type of hindrance in the air-flow generated by blower. A slope of 40 per cent was provided to the inner edge of the carrier to minimize the air-flow turbulence. Three slots of 2 mm \times 2 mm (width \times depth) with interspacing of 3 mm were provided internally from the outer end of the carrier, for placing the HV ring electrode.

High voltage charging electrode

In order to get high electrical conductivity and low resistance losses as well as ease of workability, pure Copper wire of circular section with the diameter of 2 mm was selected as an electrode material. Copper wire has low electrical resistance with easy workability, which facilitated shaping it into desired manner. Fig. 7. shows the shape and dimensions of the HV-charging copper electrode used in the present study.

Existing spray head on the mist-blower

The geometrical details of an existing spray nozzle head installed on the mist-blower unit by the manufacturer were detailed in Fig. 8. This spray head was provided with the flanged disc shape with 20 nos. of discharge outlets of 2 mm diameter, radially around the periphery. This spray head was working on

the gravity along with low head centrifugal pump driven by the engine shaft, delivering the radial spray jets into the air-flow generated by the centrifugal blower. The direction of the spray jets and the high velocity air-flow were right angles to each other, which caused the atomization of the spray fluid.

In this mechanism, the size of droplets formed was completely depending upon the velocity of the air-flow. These droplets were then carried away along with the high velocity of continuous air-blow. The developed charging system which consisted of HVDC charging circuit and electrode carrier assembly (Model-I) was fitted as an attachment to the existing engine operated knapsack mist-blower without any modification or alteration with the existing spray nozzle head.

Laboratory experimental setup

Measurement of high voltage, generated by the fabricated HVDC generator unit was one of the critical factors, since this high voltage was the basic parameter influencing the induction charging of spray (Law and Scherm, 1991; Carlton *et al.*, 1995). Similarly, the current induced in the spray was also an important factor in the induction charging, hence it has to be measured accurately (Law and Michael, 1981). The most suitable and safe method for measurement of high voltages and current related with it, was using a High Voltage Probe in combination with a Digital Multimeter unit with the compatible data logger software. Also, the Faraday's Cage was fabricated as per the requirements for the study to measure the charged spray cloud current.

The digital multimeter Model No. KM-5040T/BM-812a of make KUSAM-MECO Brymen, Ind. Ltd. was used for the

measurement of voltage and current generated by the HVDC generator unit. The DMM was equipped with 5000 counts and analog bar graph screen and also enabled with RS-232 Computer Interface-Data Logging Software which can collect data from the DMM with Infrared serial bus cable at the data collection speed of one reading per second. Fig.9 shows the face window of the Computer Interface-Data Logging Software. The general specifications of the DMM used were,

In order to measure the high voltage potential at the charging electrode in the range of kilovolts, a High Voltage Probe Model No. PD-28 of make KUSAM-MECO Brymen, Ind. Ltd. was used, in compatibility with the DMM. High voltage probe was basically a voltage divider network consisting high resistances in series form. The high voltage was applied to the voltage divider network and the corresponding current flowing through the low resistance was measured by the DMM, which has been calibrated to show corresponding high voltage.

The HV-probe has an insulated hollow body with slender shape inside which, a voltage divider network of series high resistances has fitted. The tip of probe was pointed and made of brass, as the measuring contact surface to the high voltage terminal. At the base, insulated handle was provided with the surge protector shield which assures the operator safety during measurement of such high voltages. Three cables emanated from the prob and serves as the earth and the other two for connecting DMM.

Faraday's cage

The induction spray chargeability of the developed electrostatic induction spray charging system could be measured only by measuring the charge acquisition by the spray cloud. The charge acquired by the spray cloud

was directly proportional to the charge induction capacity of the HV electric field produced around the electrode by the developed system. Faraday's Cage is one of the simple and accurate methods the charge of spray cloud, in the laboratory (Law, 1975; Almekinder *et al.*, 1992; Patel *et al.*, 2015). It could be fabricated in different shapes and sizes with different sensing elements according to the requirements of experimental setup, without violating the basic concept.

In this study, water was used as the spray fluid and it was required to measure the induced spray cloud voltage instantaneously. The Faraday's cage was designed with general thumb rules and fabricated accordingly with a Polypropylene vessel and Aluminium mesh, as illustrated in Fig. 10. The shielding Aluminium mesh was wrapped around the insulating vessel of cylindrical shape, keeping it in a horizontal position, to avoid atmospheric electric field interference to the charge collector mesh (Law and Cooper, 1988; Gupta *et al.*, 1989).

The charge collector Aluminium mesh was placed inside the vessel, vertically at marked intervals measured from the spray intake end of vessel. The cylindrical shape of the insulating vessel facilitated easy collection of spray intercepted by collector mesh, as the final outcome from the Faraday's cage was to get Charge-to-Mass ratio of the spray under test (Bayat *et al.*, 1994; Law and Cooper, 1988). CMR could be calculated from the charge collected from the spray and mass of intercepted spray (Wang *et al.*, 1995; Sumner *et al.*, 2000; Kirk *et al.*, 2001). The connections were made between the Faraday's cage and Digital Multimeter enabled with Computer Interface Data Logging Software, as ground wire to the grounded shielding mesh and positive terminal to the charge collector mesh.

The charge induction on the spray cloud by

the developed system was found to be very low. Since the droplet size formed with the air assisted mechanism of spray nozzle was heterogeneous in size (500 μm to 1500 μm) even at blower operated in full engine throttle, giving maximum air-flow velocity. The required droplet spectrum for effective induction charging was strictly 80 to 250 μm (Law and Cooper, 1988). Moreover, the dripping of spray fluid was also observed even at full throttle operation, thus lead to drop in the electrode potential.

The angular spacing between two consecutive discharge points was increased from 18° to 60° for uniform distribution of spray fluid within the air-flow. However, no any significant improvement was observed from the operation of redesigned nozzle, as the dripping was still taken place with larger droplet size, though operated at full engine throttle. Therefore, a new type of spray nozzle was designed and fabricated to satisfy the study requirements.

Development of Self-Atomizing Hydraulic Nozzle

For getting required range of fine droplet size, an entirely different type of spray nozzle was designed and fabricated (Fig. 11 and Fig. 12), consisting a single orifice for fluid discharge with 0.10 mm opening diameter, working under hydraulic pressure ranging between 2.5 to 3.0 $\text{kg}\cdot\text{cm}^{-2}$. The 12-24V DC operated low discharge high pressure diaphragm pump was selected to operate the nozzle, as it suited best for restricted space and corresponding addition in the gross weight of the whole equipment. Nozzle was fabricated with Polypropylene material, provided with internal lateral entry of spray fluid towards the discharge point. The new design helped to get hollow-cone spray pattern with fine spray. The nozzle was operated separately with diaphragm pump and all the components were

assembled together to form a single unit as Self-Atomizing Pressure operated nozzle type Electrostatic Induction Charging Knapsack Mist-Blower (Fig. 13).

Model-II: exposed electrode assembly with developed nozzle

The exposed high voltage induction charging electrode assembly as in Model I was installed for the developed nozzle. The electrode position was radially 25 mm away from the atomization zone. Three different lateral positions (0 mm, 5 mm, 10 mm and 15 mm) of the electrode ahead of the atomization zone were evaluated.

Measurement of charge induction on the spray cloud

The charge induction was measured for the different experimental setups. HVDC insulated wire electrode was mounted directly over the spray nozzle. The blower was operated at operating condition, so as to produce an air stream of velocity 60 to 70 m·s⁻¹. Faraday's cage was placed co-axially facing the air stream in front of spray nozzle at five different horizontal distances of 0.5 m, 1.0 m, 1.5 m, 2.0 m and 2.5 m. The charge induction was measured for five distinct voltage potentials of 1 kV, 2 kV, 3 kV, 4 kV and 5 kV at specific five longitudinal locations of the faraday's cage using DMM and computer-based data logging software (Laryea and No, 2002; Tongxian *et al.*, 2004; Latheef *et al.*, 2008).

Measurement of spray droplet size

The spray droplet size was measured at identical operating conditions since the spray chargeability was inversely proportional to the droplet size (Bouse, 1994; Khadir *et al.*, 1994). Bromide Photo paper of size 5 cm × 5 cm was used for capturing the droplet

spectrum. Methylene Blue dye was used for pigmenting the spray fluid (Fig. 14). Pigmented spray solution was prepared by dissolving 20 g of dry Methylene Blue dye in 1.0litre of water (Barbosa *et al.*, 2009; Celen *et al.*, 2009). High resolution Scanner was used for scanning photo papers with 1200 dpi scan resolution. Computer based image analysis software Image-J-2016, Version 1.37.1 was used to analyze the scanned images and spectrum (Jaworek *et al.*, 2009; Mishra *et al.*, 2014).

Deposition characteristics

The spray deposition was quantified in terms of deposition per unit leaf area sprayed, by Leaf-wash method. Leaf samples from treated plant targets were collected randomly and different parts of the plant surface. Dye residues were washed from the top side and under sides of the leaves separately. Dye solutions thus collected were evaluated for transmittance with a Spectrophotometer and compared with the calibration from known washed deposits to determine dye deposition on each sample (Derksen and Bode, 1986; Krause and Derksen, 1991).

1.5 g of fluorescent tracer (DAY GLO type GT-15-N Fluorescent Blaze Orange dye) was dissolved in 1000 ml of water, making concentration of tracer liquid 1500 ppm. This concentration of tracer residue on the target was analogous to pesticide active ingredient of an actual spray solution. This facilitated a direct correlation of relative deposition efficiencies of the electrostatic versus conventional spraying techniques. After spray, the spray fluid deposited on water sensitive paper or leaf surface were retrieved and the dye was extracted by washing with known quantity of double distilled water. The recovered tracer concentration was analyzed for optical density (absorbance) with Spectrophotometer. Spectrophotometer was

pre calibrated with double distilled water representing zero absorbance reading. Then further calibration was carried out in the visible region of the electromagnetic spectrum of wave length (λ) 555 nm, which is same as that of fluorescent tracer material and commercial agricultural chemicals. Solutions of known standard concentrations (ppm) of the tracer were prepared and measured for their optical density on the spectrophotometer. The concentration of the tracer of the sample was directly measured by the spectrophotometer in terms of ppm.

Statistical analysis

The Completely Randomized Design (CRD) with General Linear Model (GLM) multiple comparisons Single Factor ANOVA were done to determine whether the difference between the performances of developed models were significant. The two developed Models (I and II), charging voltages (1kV, 2kV, 3kV, 4kV and 5kV), Electrode placements (0 mm, 5 mm, 10 mm and 15 mm ahead of the spray atomization zone) and Charge carrying distances (50 cm, 100 cm, 150 cm, 200 cm and 250 cm coaxially from the nozzle tip) were the independent variables, whereas the CMR (Charge to Mass Ratio) with three replications was taken as the dependent variable for the statistical analysis. All the statistical procedures were conducted using computer-based data analysis software SPSS (Ver. 2016), IBM Inc.

Results and Discussion

The developed electrostatic spray charging system (Model II) was evaluated for CMR in comparison with existing commercial electrostatic sprayer of make Electrostatic Spraying Systems (ESS) Inc., Watkinsville (G.A.) Model-ESS-MBP90. The CMR values were measured for both developed and existing ESS sprayer at different distances (50

cm, 100 cm, 150 cm, 200 cm and 250 cm) coaxially from the spray nozzle tip and expressed in Table.2 The maximum CMR (2.12 mC.kg^{-1}) was observed at 50 cm distance away from nozzle for commercial electrostatic sprayer (ESS-MBP90), followed by developed unit (1.088 mC.kg^{-1}) at optimum operating conditions. The observed CMR values were ranged between 0.022 mC.kg^{-1} to 2.121 mC.kg^{-1} and 0.111 mC.kg^{-1} to 1.088 mC.kg^{-1} for commercial ESS sprayer and developed Model-II respectively in descending distance from the spray nozzle (Johannama *et al.*, 1991; Fritz *et al.*, 2009).

The commercial electrostatic sprayer utilizes high pressure compressed air to atomize the spray liquid with discharged rate of 150 ml.min^{-1} . On other hand the developed self-atomizing nozzle atomizes the spray liquid by virtue of hydraulic pressure through portable 12V DC diaphragm pump and was independent of air velocity. Hence the air stream from mist blower was utilized only for directing the charged spray droplets towards the target. The CMR values were measured for both developed system (for 1 kV to 5 kV and EPP 5 mm) and existing ESS sprayer at different distances (50 cm, 100 cm, 150 cm, 200 cm and 250 cm) coaxially from the spray nozzle tip.

The maximum CMR (2.12 mC.kg^{-1}) was observed at 50 cm distance away from nozzle for commercial electrostatic sprayer (ESS-MBP90), followed by prototype (1.088 mC.kg^{-1}) at optimum operating conditions (Fig. 37). The observed CMR values were ranged between 0.022 mC.kg^{-1} to 2.121 mC.kg^{-1} and 0.111 mC.kg^{-1} to 1.088 mC.kg^{-1} for commercial ESS sprayer and developed Model-II respectively from 250 cm to 50 cm distance from the spray nozzle (Law and Cooper, 1988; Alamuhanna and Maghirang, 2010).

Table.2 CMR comparison between commercial and developed system

Sprayer Model	CMR (mC.kg ⁻¹) at distances from the nozzle				
	50 cm	100 cm	150 cm	200 cm	250 cm
a. Commercial ESS	2.121	0.561	0.221	0.044	0.022
b. Developed Model II	1.088	0.677	0.444	0.177	0.111

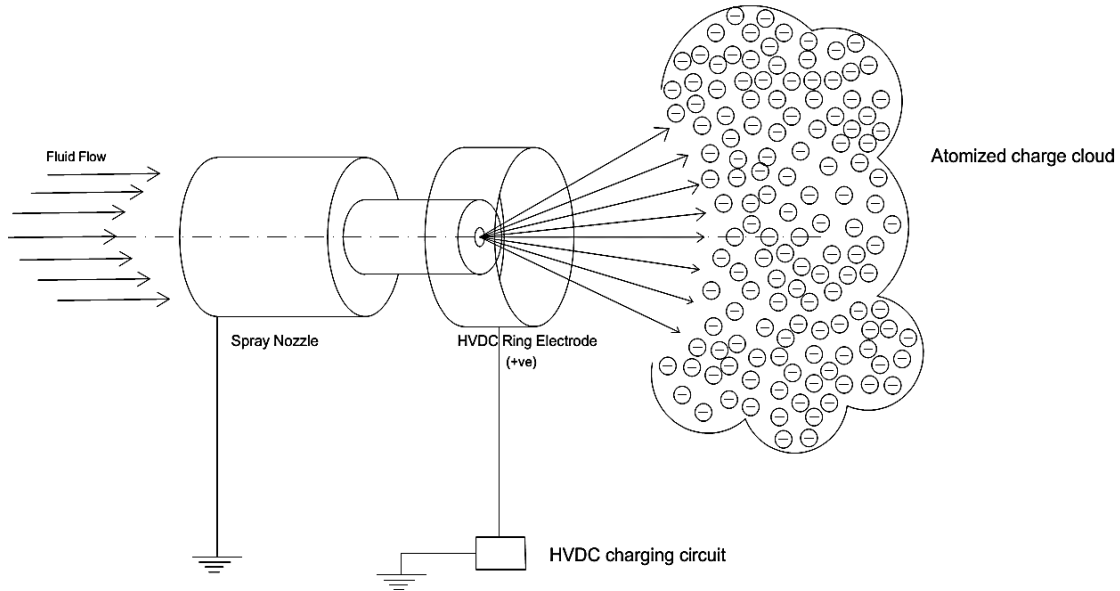

Fig.1 Electrostatic induction spray charging system

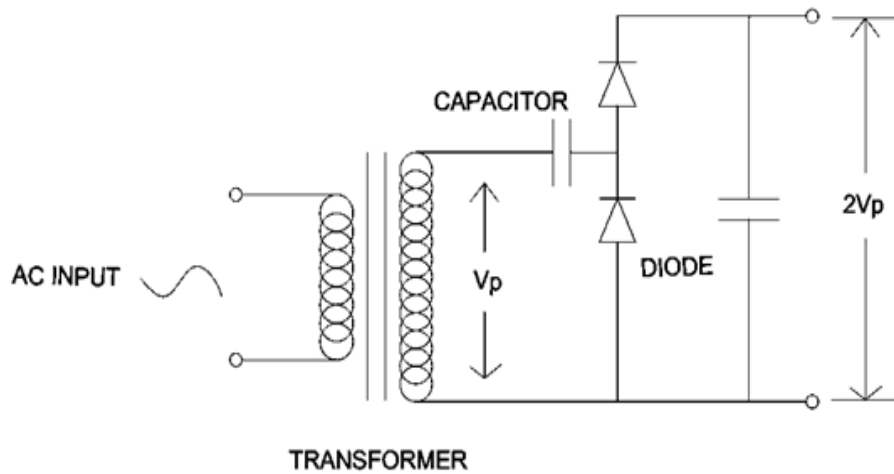

Fig.3 Diode-Pump Rectifier

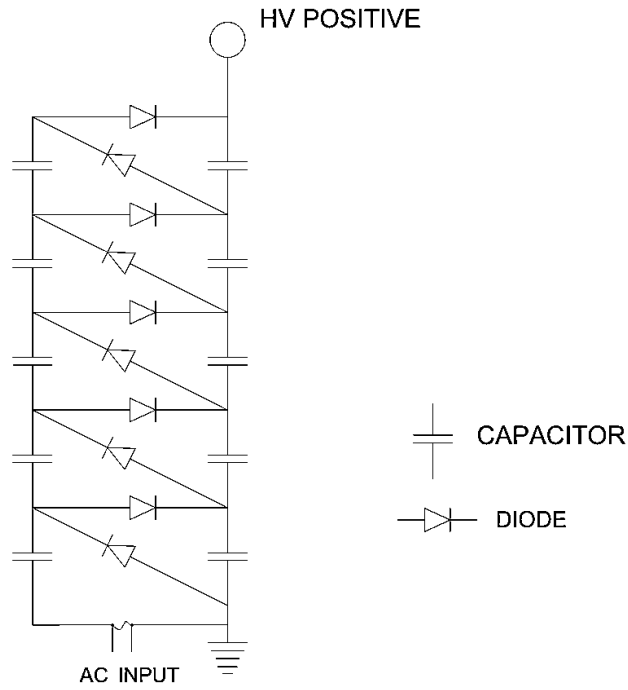

Fig.4 Cockcroft-Walton voltage multiplier

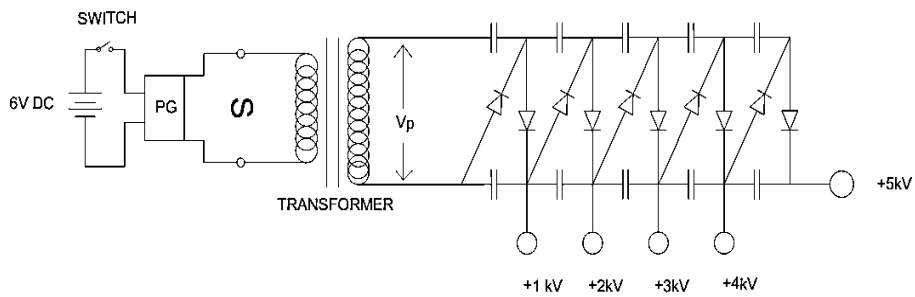

Fig.5 High Voltage generator

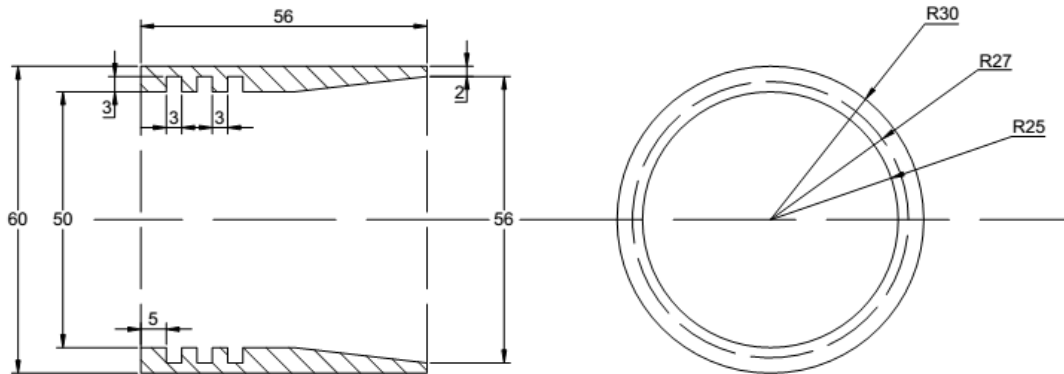

Fig.6a Exposed electrode assembly (Sectional view)

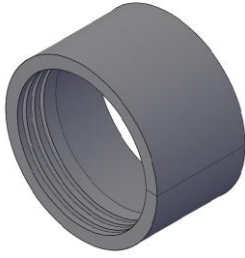

Fig.6b Exposed electrode assembly (CAD Isometric view)

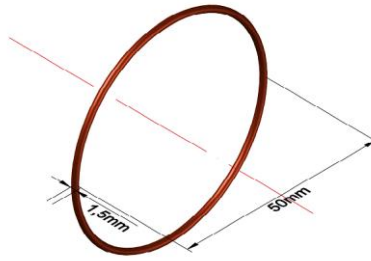

Fig.7 HV-Charging electrode

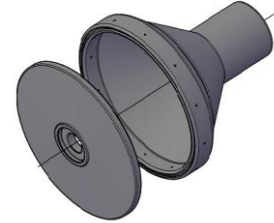

Fig.8 Existing nozzle assembly of the knapsack mist blower

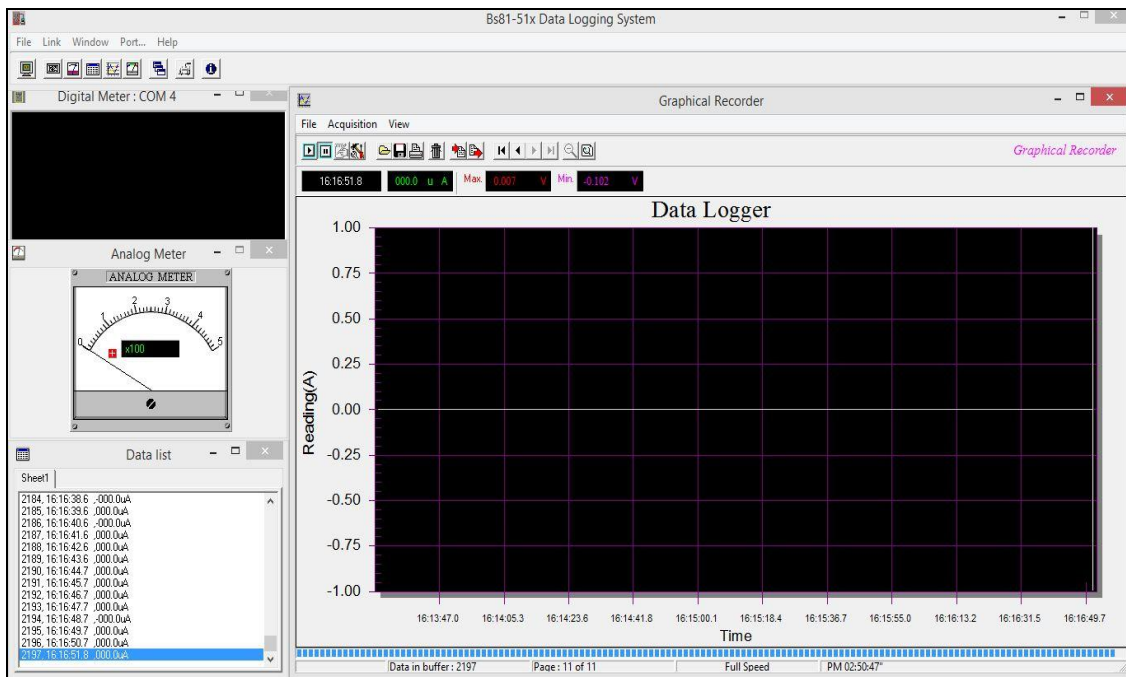

Fig.9 RS-232 Computer Interface-Data Logging Software

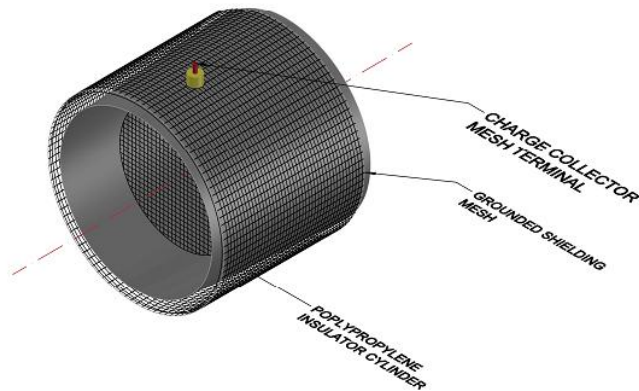

Fig.10 Schematics of Faraday' Cage

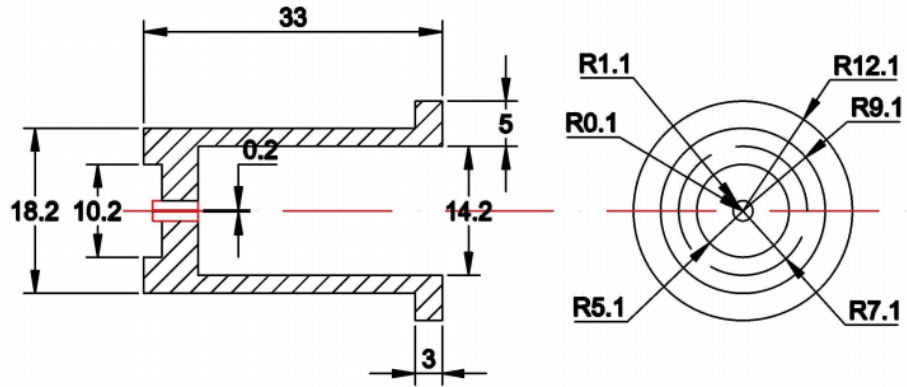

Fig.11 Self-Atomizing hydraulic nozzle

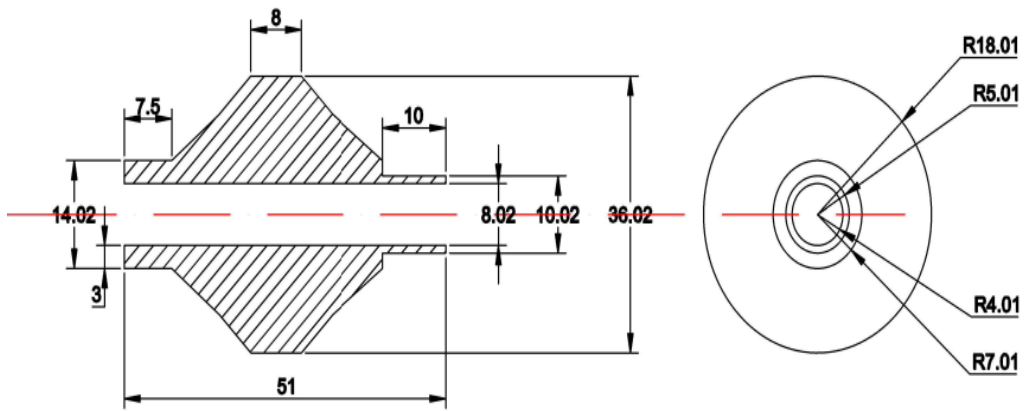

Fig.12 Adapter for nozzle fitment (Sectional View)

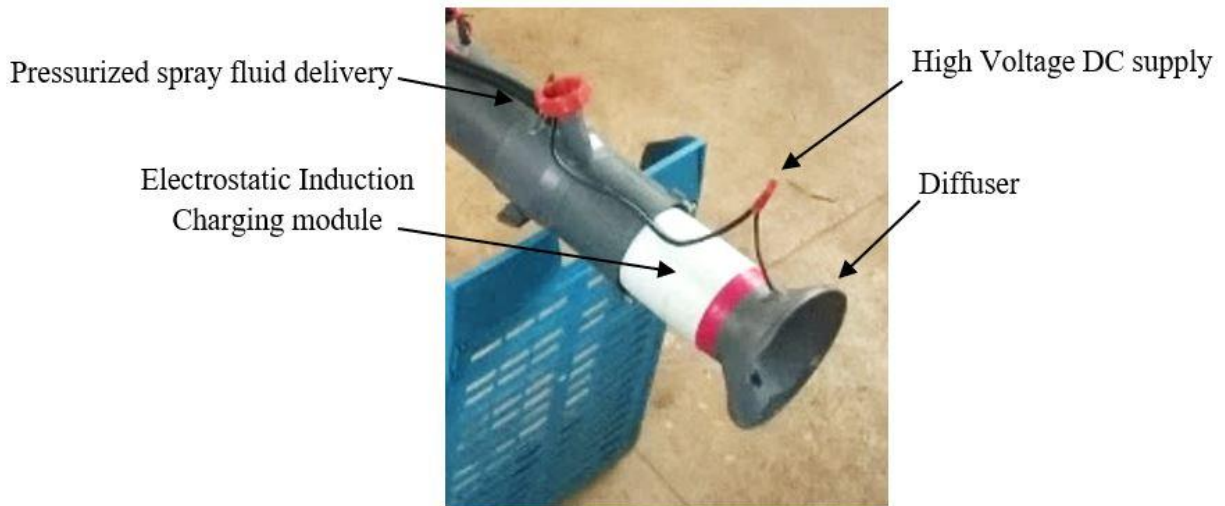

Fig.13 Electrostaticinduction charging unit attached to the powered mist blower

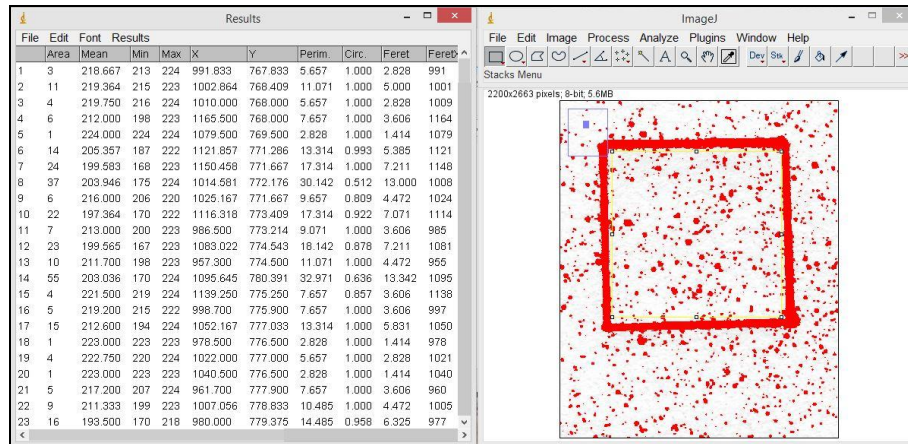

Plate.1 Image-J-2016 software interface during droplet spectrum analysis

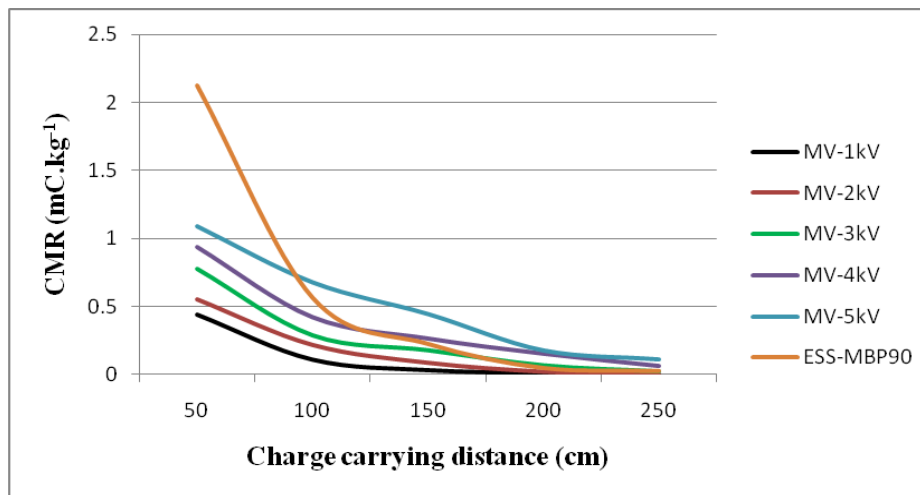

Fig.15 Charge carrying capacity: Developed system (Model II) with five charging voltages Vs. Commercial ESS MBP90 sprayer

The developed electrostatic spray charging system (Model-II) was evaluated for CMR in comparison with existing commercial electrostatic sprayer of make Electrostatic Spraying Systems (ESS) Inc., Watkinsville (G.A.) Model-ESS-MBP90.

The maximum CMR (2.12 mC.kg^{-1}) was observed at 50 cm distance away from nozzle for commercial electrostatic sprayer (ESS-MBP90), followed by developed unit (1.088 mC.kg^{-1}) at optimum operating conditions. The CMR were ranged between 0.022 mC.kg^{-1} to 2.12 mC.kg^{-1} and 0.111 mC.kg^{-1} to 1.088 mC.kg^{-1} for commercial ESS sprayer and developed Model-II respectively in

descending distance from the spray nozzle. It was observed that the CMR of the developed system surpassed that of the commercial ESS from a distance 100 cm onwards from the nozzle tip. The CMR for commercial unit radically lowered from 2.12 mC.kg^{-1} to 0.561 mC.kg^{-1} for the corresponding increase in the distance from the nozzle tip (50 cm to 100 cm).

The developed system shown significantly low rate of CMR reduction (1.088 mC.kg^{-1} to 0.111 mC.kg^{-1}) in respect of distances which in turn reflected its better charge carrying capacity than the commercial unit (2.12 mC.kg^{-1} to 0.022 mC.kg^{-1}).The cost

effectiveness of the developed system was estimated in terms of initial cost of the equipment, quantity of chemical used, cost of cultivation and environmental contamination. The cost of developed system was 1/8th of that of the commercial electrostatic (ESS-MBP90) system without compromising the performance viz. charge induction, deposition efficiency and in environment friendly application.

References

- Alamuhanna, E. A. and Maghirang, R. G. 2010. Measuring the electrostatic charge of airborne particles. *J. Fd., Agric. & Environ.*, 8(3): 1033-1036.
- Almekinders, H., Ozkan, H. E., Reichard, D. L., Carpenter, T. G. and Brazee, R. D. 1992. Spray deposition patterns of an electrostatic atomizer. *Trans. ASAE*. 36(6): 1361-1367.
- Anantheswaran, R. C. and Law, S. E. 1989. Electrostatic spraying of turf grass. *VSGA, Green Section Project Rec.* pp.1-4.
- Barbosa, R. N., Griffin, J. L. and Hollier, C. A. 2009. Effect of spray rate and Method of application in spray deposition. *Appl. Eng. in Agric.* American Society of Agricultural and Biological Engineers. 25(2): 181-184.
- Bayat, A., Zeren, Y. and Rifat, M. V. 1994. Spray deposition with conventional and electrostatically charged spraying in citrus trees. *Agric. Mech. Asia, Afr. and Latin Am.* 25(4): 35-39.
- Bode, L. E. and Bowen, H. D. 1991. Spray distribution and charge-mass ratio of electrostatically charged agricultural sprays. *Trans. ASAE*. 34(5): 1928-1934.
- Bouse, L. F. 1994. Effect of nozzle type and operation on spray droplet size. *Trans. ASAE*. pp.1389-1400.
- Carlton, J. B. and Bouse, L. F. 1980. Electrostatic spinner-nozzle for charging serial sprays. *Trans. ASAE*. 37(5): 1369-1374.
- Carlton, J. B., Bouse, L. F. and Kirk, I. W. 1995. Electrostatic charging of aerial spray over cotton. *Trans. ASAE*. 38(6): 1641-1645.
- Celen, H. I., Durgut, M. R., Gurkan, G. A. and Erdal, K. 2009. Effect of air assistance on deposition distribution of spraying by tunnel type sprayer. *Afr. J. Agric. Res.* 4(12): 1392-1397.
- Derksen, R. C. and Bode, L. E. 1986. Droplet size comparison from Rotary atomizers. *Trans. ASAE*. 29(5): 1204-1207.
- Fritz, B. K., Parker, C., Lopez, J. D., Hoffmann, W. C. and Schleider, P. 2009. .deposition and Droplet sizing characterization of a laboratory spray table. *Appl. Eng. in Agric.* American Society of Agricultural and Biological Engineers. 25(2): 175-180.
- Gupta, C. P., Alamban, R. B. and Dante, E. T. 1994. Development of knapsack electrostatic spinning disc sprayer for herbicide application in rice. *Agric. Mech. Asia, Afr. and Latin Am.* 25(4): 31-37.
- Gupta, C. P., Singh, G., Parameshwarkumar, M. and Ganapathy, S. 1989. Farmer driven electrostatic low-volume sprayer. *Innovative Scient. Res. U.S.-Israel CDR program, AIT, Bangkok.* pp.1-21.
- Jaworek, A., Sobczyk, A. J., Krupa, A., Lackowski, M. and Czech, T. 2009. Electrostatic deposition of nano-thin films on metal substrate. *Bull. The Polish Sci.* 57(1): 63-70.
- Johannama, M. R., Watkins, A. P. and Yule, A. J. 1991. Examination of electrostatically charged spray for agricultural spraying applications. *ILASS-Europe '99.* pp.1-6.
- Jorg, F. and Launter, S. 2006. Electrical signals and their physiological significance in plants. *Plant, Cell and Environ.* 30(1): 249-257.

- Khadir, A. I., Carpenter, T. G. and Reichard, D. L. 1994. Effects of air jets on deposition of charged spray in plant canopies. *Trans. ASAE*. 37(5): 1423-1429.
- Kihm, K. D., Kim, B. H. and McFarland, A. R. 1992. Atomization, Charge and Deposition characteristics of bipolarly charged aircraft sprays. *Atomization and Sprays*. 2: 463-481.
- Kirk, I. W., Hoffmann, W. C. and Carlton, J. B. 2001. Aerial electrostatic spray system performance. *Trans. ASAE*. 44(5): 1089-1092.
- Krause, C. R. and Derksen, R. C. 1991. Comparison of electrostatic and cold-fog sprayers using cold-field emission scanning electron microscopy and energy dispersive X-ray microanalysis. *USDA Agric. Res. Serv., Madison-Wooster, USA*. pp.1-7.
- Lane, M. D. and Law, S. E. 1982. Transient charge transfer in living plants undergoing electrostatic spraying. *Trans. ASAE*. 31(4): 1148-1155.
- Laryea, G. N. and No, S. Y. 2002. Spray characteristics of charge injected electrostatic pressure-swirl nozzle. *ILASS-Zaragoza, Europe*. 9(11): 1-6.
- Latheef, M., Kirk, I. W., Carlton, J. B. and Hoffmann, W. C. 2008. Aerial electrostatic charged sprays for deposition and efficacy against sweet potato whitefly (*Bemisia tabaci*) on cotton. *Pest Mgmt. Sci., Wiley Interscience*. 65: 744-752.
- Law, S. E. 1975. Electrostatic induction instrument for tracking and charge measurement of airborne agricultural particulates. *Trans. ASAE*. pp.40-47.
- Law, S. E. and Cooper, S. C. 1988. Depositional characteristics of charged and uncharged droplets applied by an orchard air carrier sprayer. *Trans. ASAE*. 31(4): 984-989.
- Law, S. E. and Michael, D. L. 1981. Electrostatic deposition of pesticide spray onto foliar targets of varying morphology. *Trans. ASAE*. pp.1441-1445.
- Law, S. E. and Scherm, H. 1991. Electrostatic application of a plant-disease bio-control agent for prevention of fungal infection through stigmatic surfaces of blueberry. pp.1-14
- Luciana, N. and Cramariuc, R. 2009. Contribution about the electrohydrodynamic spraying. *U.P.B. Sci. Bull., Ser.-C*. 71(3): 205-213.
- Mamidi, V., Ghanashyam, C., Patel, M. K., Reddy, V. and Kapur, P. 2012. Electrostatic hand pressure swirl nozzle for small crop growers. *Int. J. Appl. Sci. & Tech., Res. Excellence*. 2(2): 164-168.
- Maynagh, B., Ghobadian, B., Johannama, M. and Hashjin, T. 2009. Effect of electrostatic induction parameters on droplet charging for agricultural application. *J. Agric. Sci. & Tech*. 11(1): 249-257.
- Mishra, P.K., Singh, M., Sharma, A., Sharma, K. and Singh, B. 2014. Studies on effect of electrostatic spraying in orchards. *Agric. Eng. Int., J. CIGR*. 16(3): 60-69.
- Mouel, J. L., Gibert, D. and Poirier, J. P. 2010. On transient electric potential variations in standing tree and atmospheric electricity. *Comptes Rendus Geosci., Elsevier*. 342: 95-99.
- Oerke, C. N., 2006. Crop losses to pests. *J. Agric. Sci.* Cambridge University Press, 144(1), pp. 31-43.
- Oyarace, P. and Luis, G. 2010. Electrical signals in Avocado trees – Responses to light and water availability conditions. *Plant Signaling and Behavior, Landes Biosci*. 5(1): 34-41.
- Patel, M. K., Sahoo, H. K., Nayak, M. K., Kumar, A., Ghanashyam, C. and Amod, K. 2015. Electrostatic Nozzle: New

- Trends in Agricultural Pesticide Spraying. *Int. J. Electr. & Electronics Eng.*, pp.6-11.
- Robson, S., Mauri, M. T., Fernandes, H. C., Monteiro, P. M., Rodrigues and Cleyton, B. A. 2013. Parameters of electrostatic spraying and its influence on the application efficiency. *Rev. Ceres, Vicosa-Brazil*, 60(4): 474-479.
- Smith, D. B., Goering, C. E., Liljeldahl, L. A., Reichard, D. L. and Gebhardt, M. R. 1977. AC charging of Agricultural sprays. *Trans. ASAE*. 34(6): 1002-1007.
- Sumner, H. R., Herzog, G. A., Sumner, P. E., Bader, M. and Mullinix, B. G. 2000. Chemical application equipment for improved deposition in cotton. *J. Cott.Sci.*4:pp.19-27.
- Tong-Xian, L., Philip, A. S. and Conner, J. M. 2004. Evaluation of spray deposition on plant foliage with self-adhesive paper targets. *Subtropical Plant Sci.* 36: 39-43.
- Wang, L., Zhang, N., Slocombe, J. W., Thierstein, G. E. and Kuhlman, D. K. 1995. Experimental analysis of spray distribution pattern uniformity for agricultural nozzles. *Appl. Eng. in Agric.* 25(2): 50-55.
- Yu, R., Zhou, H. and Zheng, J. 2011. Design and experiments on droplet charging device for high range electrostatic sprayer. *Pesticides in Modern Wld. – Pesticide Use and Mgmt.*, pp.137-148.

How to cite this article:

Dipak S. Khatawkar, D. Dhalin and Shaji James. P. 2020. Electrostatic Conversion Kit for Conventional Knapsack Mist-blower:Development and Performance Evaluation. *Int.J.Curr.Microbiol.App.Sci.* 9(03): 2227-2242. doi: <https://doi.org/10.20546/ijcmas.2020.903.254>