

Review Article

<https://doi.org/10.20546/ijcmas.2018.709.138>

A Review Study on Existing Manually Operated Seed Planter for Marginal Farmers of India

Uday Veer Singh* and Sheen C. Moses

Department of Farm Machinery & Power Engineering, VIAET, SHUATS,
Allahabad, U.P., India

*Corresponding author

ABSTRACT

A review of manually operated planting machines in India is presented. The present study show in general that the suitability of manually operated planting machines for different seed and land holdings. Farm mechanization is an important element of agriculture. Mechanization of agriculture is an essential input in modern agriculture. Mechanization also helps in improving utilization efficiency of other inputs, safety, and comfort of the agricultural worker, improvement in the quality and value addition of the produce. Looking at the pattern of land holdings in India, it may be noted that about 84% of holdings are below one hectare. In the existing scenario of the land fragmentation and resulting continued shrinkage of average size of operational holdings, percentage of marginal, small and semi medium operational land holdings is likely to increase. Such small land holding makes individual ownership agriculture machinery uneconomic and operationally unavailable. The basic objective of sowing operation is to put the seed in rows at desired depth and seed to seed spacing, cover the seeds with soil and provide proper compaction over the seed. The recommended row to row spacing, seed rate, seed to seed spacing and depth of seed placement vary from crop to crop and for different agro-climatic conditions to achieve optimum yields. Seed sowing devices plays a wide role in agriculture field. Here in this study efforts are taken to design and develop a manually operated seed planting machine which is suitable for marginal land holdings and plant the seed at specific distance with specific quantity and reduce the requirement of seed per unit area and with suitable furrow covering device.

Keywords

Farm mechanization,
Marginal farmers,
Seed planter, Sowing
methods

Article Info

Accepted:
08 August 2018
Available Online:
10 September 2018

Introduction

Mechanization in agriculture holds the key for sustainable development in the terms of increasing the production by timely farm operations, reducing losses, reducing the cost of operations by ensuring better management of costly inputs and enhancing the productivity of natural resources besides it

helps in reducing drudgery in farm operations. Mechanized agricultural practices and operations have been adopted by the farming community at varying level of adoption, which represents the varying scenario across different regions in the country.

The agricultural has always been the backbone of India's sustained growth. As the population

of India continues to grow, the demand for produce grows as well. Hence, there is a greater need for multiple cropping in the farms and this in turn requires efficient and time saving machines. The paper discusses different types of seed sowing machine which will be helpful for the agriculture industry to move towards mechanization.

Traditional Sowing Methods: Traditional methods include broadcasting manually, opening furrows by a country plough and dropping seeds by hand and dropping seeds in the furrow through a bamboo/metal funnel attached to a country plough. For sowing in small areas dibbling i.e., making holes or slits by a stick or tool and dropping seeds by hand, is practiced.

Multi row traditional seeding devices with manual metering of seeds are quite popular with experienced farmers. In manual seeding, it is not possible to achieve uniformity in distribution of seeds. A farmer may sow at desired seed rate but inter-row and intra-row distribution of seeds is likely to be uneven resulting in bunching and gaps in field.

Traditional sowing methods have following limitations:

In manual seeding, it is not possible to achieve uniformity in distribution of seeds.

A farmer may sow at desired seed rate but inter-row and intra-row distribution of seeds is likely to be uneven resulting in bunching and gaps in field.

Poor control over depth of seed placement. Labor requirement is high because two persons are required for dropping seed and fertilizer. The effect of inaccuracies in seed placement on plant stand is greater in case of crops.

The methodology followed during this research work is discussed as under in terms of different type of manually operated seed planter.

Rotary diddler

The rotary dibbler is a manually operated push type device for dibbling of medium and bold size seeds. It consists of a rotating dibbling head with penetrating jaws, covering-cum-transport heel, seed hopper with cell type wooden roller and a handle. Except seed roller, which is made of good quality wood, all the other parts are fabricated from mild steel.

The number of jaws varies from five to eight among various designs, depending upon seed to seed distance. For its operation, the hopper is filled with seeds and transport-cum covering wheel is drawn to rear side. The dibbler is then pushed forward in the direction of travel with covering cum transport wheel behind the dibbling head. The jaws penetrate into the soil and automatically drop the seeds.

Uses: For sowing of medium and bold vegetable and cereal seeds

Manual seed and fertilizer drill

This is a small manually operated single row seed cum fertilizer drill in which fluted roller metering mechanism is provided. A ground wheel is provided to drive the metering rollers. Seed and fertilizer are stored in a small hopper and a long beam is provided by which the implement could be pulled by one operator. Another worker guides the machine. Due to the provision of fluted rollers, it is suited for drilling soybean maize, pigeon pea, sorghum, green gram, Bengal gram, wheat etc. Shoe type furrow openers are provided for easy operation.

Rotary diddler



Specifications:

Seed	Metering cell type wooden roller, six cells
Weight (kg)	21.5
Seed placement device	jaw type
Jaw spacing (mm)	225
Capacity (ha/day)	0.6 to 1.0
Labor requirement (man-h/ha)	27

Manual seed and fertilizer drill



Specifications:

Length (mm)	1800
Width (mm)	600
Height (mm)	950
Weight (kg)	17
Metering roller diameter(mm)	147
Operating speed(km/h)	2.6
Labor requirement (man-h/ha)	40

Manual oilseed drill



Specifications:

Length(mm)	1270
Width(mm)	520
Height(mm)	1000
Weight (kg)	9.0
Power Transmission	Through chain and sprocket
Seeding mechanism	Fluted roller with narrow flutes
Hooper capacity(kg)	2

Single row manually operated multi crop planter

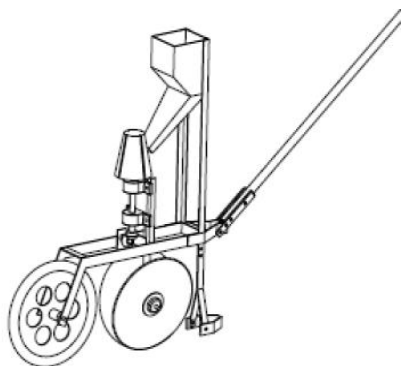

<i>Specifications:</i>	
Length (mm)	1520
Width (mm)	1000
Height (mm)	600
Weight (kg)	18
Metering device	Cone with slots, 4.5 cm top diameter, 13.5cm bottom diameter, 15cm height, 4 grooves
Runner wheel diameter(mm)	40
Power transmission	Chain & sprocket
Transmission ratio	1:1

Low cost maize planter



<i>Specifications:</i>	
Length (cm)	137.2
Width (cm)	60.9
Seed hopper (cm)	20.3 height, 21.6 and 17 diameter
Plate type seed metering device (cm)	16.8 diameter, 8 cell
Seed tube (cm)	30.48 height and diameter 2.54
Sweep type bed former (cm)	Diameter 25.4
Runner wheel (cm)	Diameter 40.64
Handle (cm)	Length 60.9 and 2.54 diameter
Depth Control devices (cm)	Length 33

Uses: It is suitable for drilling seeds of soybean, wheat, etc along with fertilizer.

Manual oilseed drill

The equipment consists of a seed box attached to the main frame of a hand wheel hoe. A fluted roller assembly is provided at the

bottom of the seed box. Fluted roller is rotated with the help of chain and sprockets from the ground wheel. The seed rate can be adjusted with the help of a lever provided on the seed box. The fluted roller used for sowing rape seed and mustard has 8 flutes. Each flute is 3 mm wide and 2 mm deep. The diameter of the fluted roller is 50 mm and its length, 32mm.

For operation, the machine is pulled by rope attached to the hook of machine by one man and other person steers the machine by holding it by the handle.

Uses: Manual oilseed drills are used for sowing rapeseed and mustard. By changing the fluted roller Position, other crops like wheat, moong etc. can also be sown. It is also suitable for inter-row sowing.

Single row manually operated multi crop planter

A manually operated planter was developed aiming at small and marginal farmers with a fabrication cost of Rs. 4500 and a draft of 143 N. Cone mechanism was developed to suit different crops without changing metering mechanism. The weight of the planter is found to be 18 kg with a hopper capacity of 2 kg. The planter is useful equipment for the marginal farmers who cannot purchase heavy machinery.

Low cost maize planter

A low cost manually operated push type maize planter was designed, developed and tested in the testing bed of the department of Farm Power and Machinery, Bangladesh Agricultural University, which reduces these problems. The maize planter consists of two runner wheels, a seed hopper, an inclined plate type seed metering device, a seed tube, a pair of bed former and handle. Power is transmitted from the runner wheel to the metering device through bevel gear mechanism. UniGreen (NK-41) hybrid maize seeds were used to test the planter. The planter was calibrated in the lab to maintain the desired seed rate of 25-30 kg/ha. In the laboratory test, the effective field capacity, field efficiency, average distance of dropped seed, plant population and missing rate were found as 0.128 ha/hr, 76.5%, 22.5 cm, 8

plants/m², and 13.43% respectively for first maize planter. The operational cost of the first maize planter was achieved as 410 Tk/ha whereas in manual planting of maize it is 5250 Tk/ha, thus the planter may save about 92% cost for maize establishment. The pushing force of the maize planter was 90 N, which is quite low to operate by a female person. The machine might be acceptable since it is easy to operate, simple in design and mechanism, light in weight, requires less labor and cost of planting after further trial in the farmer's field.

As requirement of planting equipment, planter is widely required in today's modern port. Wide ranges applications of planter, and the work environment is generally more difficult, to achieve maximum efficiency, extend equipment life, improve the quality of operation, reduces operating costs has been the goal of engineering and technical personnel. Analyze and resolve the impact normal operation of the main problems, to ensure the good functioning of device. To fulfil above requirement it is to be needed further proper designing of manually operated seed planter which is desired for the application keeping all parameters in mind and by inventing new approaches towards better design.

References

- Ani, O. A., B. B. Uzoejinwa and N. F. Anochili (2016) design, construction and evaluation of a vertical plate maize seed planter for gardens and small holder farmers. Nigerian Journal of Technology (NIJOTECH) Vol. 35, No. 3, July 2016, pp. 647 – 655.
- Rabbani, M. A., Hossain, M. M., Asha, J. F. & Khan, N. A. (2016). Design and development of a low cost planter for maize establishment. Journal of

- Science, Technology and Environment Informatics, 04(01), 270-279.
- Ramesh, D., H.P. Girishkumar (2014) Agriculture Seed Sowing Equipments: A Review. *International Journal of Science, Engineering and Technology Research (IJSETR)*, Volume 3, Issue 7 pp. 1987-1992.
- Srigiri D., *et al.*, (2016) Development of Single Row Manually Operated Multi Crop Planter. *International Journal of Agriculture Sciences*, Volume 8, Issue 30, pp. 1632-1634.

How to cite this article:

Uday Veer Singh and Sheen C. Moses. 2018. A Review Study on Existing Manually Operated Seed Planter for Marginal Farmers of India. *Int.J.Curr.Microbiol.App.Sci.* 7(09): 1168-1173. doi: <https://doi.org/10.20546/ijcmas.2018.709.138>